

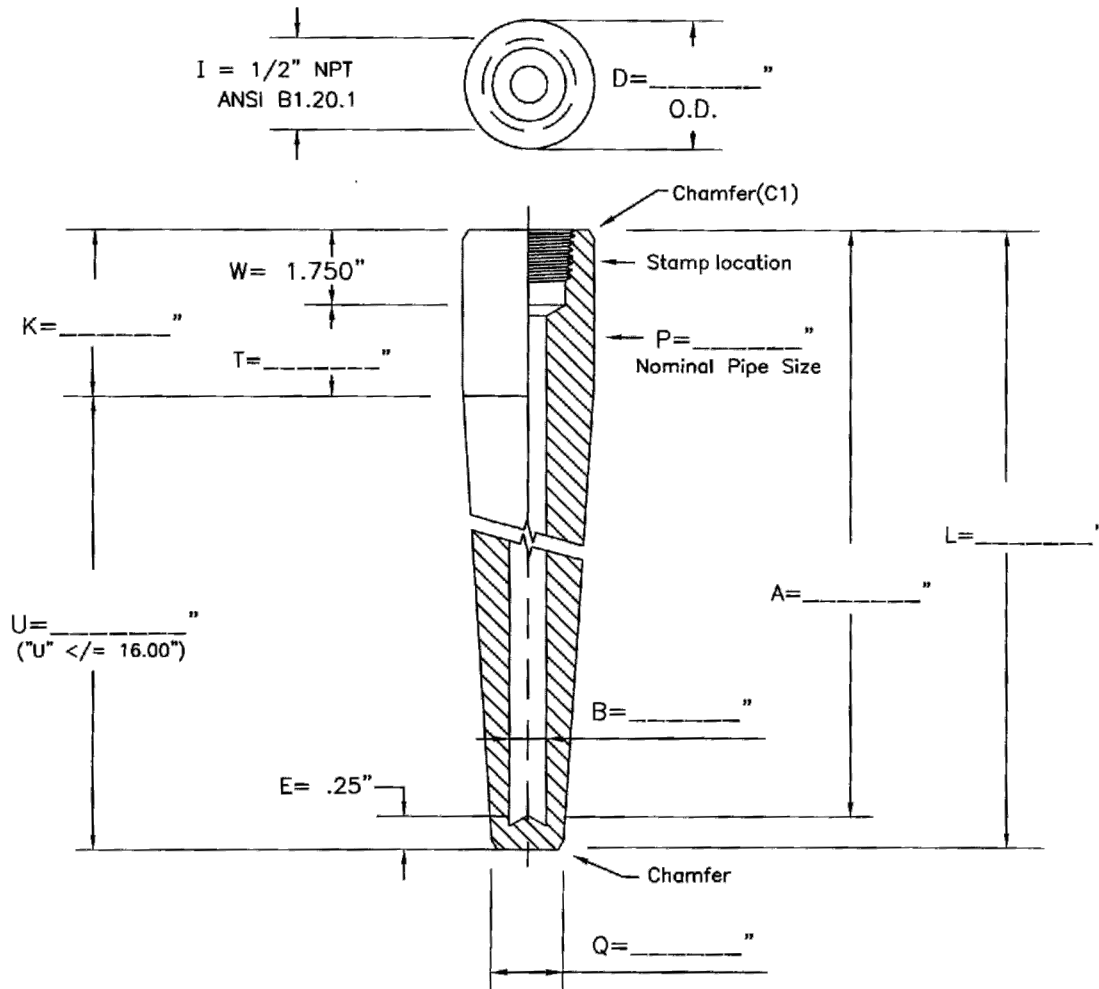

THERMOCOUPLE TECHNOLOGY, INC.

Weld-In
.260" Bore



<p><u>3/4" NPS Process Connection</u> Style 10081 No Lag Style 10089 Lagging Extension</p> <p><u>1" NPS Process Connection</u> Style 10082 No Lag Style 10090 Lagging Extension</p> <p><u>1.375" O.D. Process Connection</u> Style 10083 No Lag Style 10091 Lagging Extension</p> <p><u>1.5" O.D. Process Connection</u> Style 10084 No Lag Style 10092 Lagging Extension</p>	<p>1. BORE (B) = .260"</p> <p>2. MANUFACTURER'S STANDARD O.D.s:</p> <table border="1"> <thead> <tr> <th>a. NPS (P)</th> <th>D</th> <th>Q</th> </tr> </thead> <tbody> <tr> <td>3/4"</td> <td>1.050"</td> <td>.625"</td> </tr> <tr> <td>1"</td> <td>1.315"</td> <td>.625"</td> </tr> <tr> <th>b. O.D. (P)</th> <td></td> <td></td> </tr> <tr> <td>1.375"</td> <td>1.375"</td> <td>.625"</td> </tr> <tr> <td>1.5"</td> <td>1.500"</td> <td>.625"</td> </tr> </tbody> </table> <p>3. TOLERANCES: Reference document Series W</p>	a. NPS (P)	D	Q	3/4"	1.050"	.625"	1"	1.315"	.625"	b. O.D. (P)			1.375"	1.375"	.625"	1.5"	1.500"	.625"
a. NPS (P)	D	Q																	
3/4"	1.050"	.625"																	
1"	1.315"	.625"																	
b. O.D. (P)																			
1.375"	1.375"	.625"																	
1.5"	1.500"	.625"																	

STYLES 10081, 10089, 10082, 10090
10083, 10091, 10084, 10092

Thermocouple Technology, Inc.
350 New Street
Quakertown, Pa 18951
Phone: 215-529-9394 FAX: 215-529-9397 www.tteconline.com