

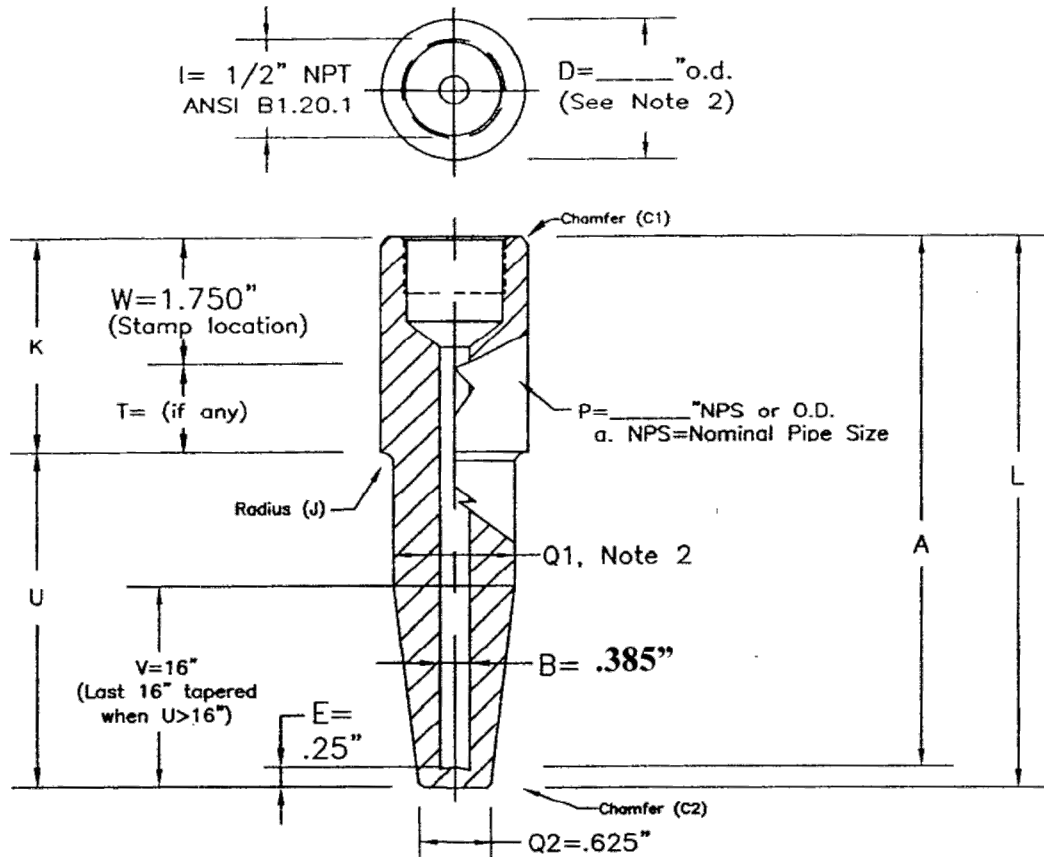

THERMOCOUPLE TECHNOLOGY, INC.

Socket-Weld

Tapered
.385" Bore



<p><u>3/4" NPS Process Connection</u> Style 10075 No Lag Style 10079 Lagging Extension</p> <p>Specifications: See Notes 1,2.a & 3</p>	<p>1. STANDARD BIMET LENGTHS:</p> <table border="0"> <tr> <td colspan="2"></td> <td colspan="2">a. No Lag "T"</td> <td colspan="2">b. With Lag "T"</td> <td colspan="2"></td> </tr> <tr> <td>"A"</td> <td>"U"</td> <td>"L"</td> <td>"A"</td> <td>"U"</td> <td>"T"</td> <td>"L"</td> <td></td> </tr> <tr> <td>4"</td> <td>2.5</td> <td>4.25"</td> <td>6"</td> <td>2.5</td> <td>2</td> <td>6.25"</td> <td></td> </tr> <tr> <td>6"</td> <td>4.5</td> <td>6.25"</td> <td>9"</td> <td>4.5</td> <td>3</td> <td>9.25"</td> <td></td> </tr> <tr> <td>9"</td> <td>7.5</td> <td>9.25"</td> <td>12"</td> <td>7.5</td> <td>3</td> <td>12.25"</td> <td></td> </tr> <tr> <td>12"</td> <td>10.5</td> <td>12.25"</td> <td>15"</td> <td>10.5</td> <td>3</td> <td>15.25"</td> <td></td> </tr> <tr> <td>15"</td> <td>13.5</td> <td>15.25"</td> <td>18"</td> <td>13.5</td> <td>3</td> <td>18.25"</td> <td></td> </tr> <tr> <td>18"</td> <td>16.5</td> <td>18.25"</td> <td>24"</td> <td>19.5</td> <td>3</td> <td>24.25"</td> <td></td> </tr> <tr> <td>24"</td> <td>22.5</td> <td>24.25"</td> <td></td> <td></td> <td></td> <td></td> <td></td> </tr> </table> <p>2. MANUFACTURER'S STANDARD O.D.s:</p> <table border="0"> <tr> <td>a. NPS</td> <td>"D"</td> <td>"Q1"</td> </tr> <tr> <td>3/4"</td> <td>1.050"</td> <td>.750"</td> </tr> <tr> <td>1"</td> <td>1.315"</td> <td>1.00"</td> </tr> <tr> <td>1-1/4"</td> <td>1.660"</td> <td>1.12"</td> </tr> <tr> <td>1-1/2"</td> <td>1.900"</td> <td>1.37"</td> </tr> </table> <p>3. TOLERANCES: Reference document: Series S</p>			a. No Lag "T"		b. With Lag "T"				"A"	"U"	"L"	"A"	"U"	"T"	"L"		4"	2.5	4.25"	6"	2.5	2	6.25"		6"	4.5	6.25"	9"	4.5	3	9.25"		9"	7.5	9.25"	12"	7.5	3	12.25"		12"	10.5	12.25"	15"	10.5	3	15.25"		15"	13.5	15.25"	18"	13.5	3	18.25"		18"	16.5	18.25"	24"	19.5	3	24.25"		24"	22.5	24.25"						a. NPS	"D"	"Q1"	3/4"	1.050"	.750"	1"	1.315"	1.00"	1-1/4"	1.660"	1.12"	1-1/2"	1.900"	1.37"
		a. No Lag "T"		b. With Lag "T"																																																																																				
"A"	"U"	"L"	"A"	"U"	"T"	"L"																																																																																		
4"	2.5	4.25"	6"	2.5	2	6.25"																																																																																		
6"	4.5	6.25"	9"	4.5	3	9.25"																																																																																		
9"	7.5	9.25"	12"	7.5	3	12.25"																																																																																		
12"	10.5	12.25"	15"	10.5	3	15.25"																																																																																		
15"	13.5	15.25"	18"	13.5	3	18.25"																																																																																		
18"	16.5	18.25"	24"	19.5	3	24.25"																																																																																		
24"	22.5	24.25"																																																																																						
a. NPS	"D"	"Q1"																																																																																						
3/4"	1.050"	.750"																																																																																						
1"	1.315"	1.00"																																																																																						
1-1/4"	1.660"	1.12"																																																																																						
1-1/2"	1.900"	1.37"																																																																																						
<p><u>1" NPS Process Connection</u> Style 10076 No Lag Style 10080 Lagging Extension</p> <p>Specifications: See Notes 1,2.a & 3</p>																																																																																								

STYLE 10075, 10079, 10076, 10080

Thermocouple Technology, Inc.
350 New Street
Quakertown, Pa 18951
Phone: 215-529-9394 FAX: 215-529-9397 www.tteconline.com