

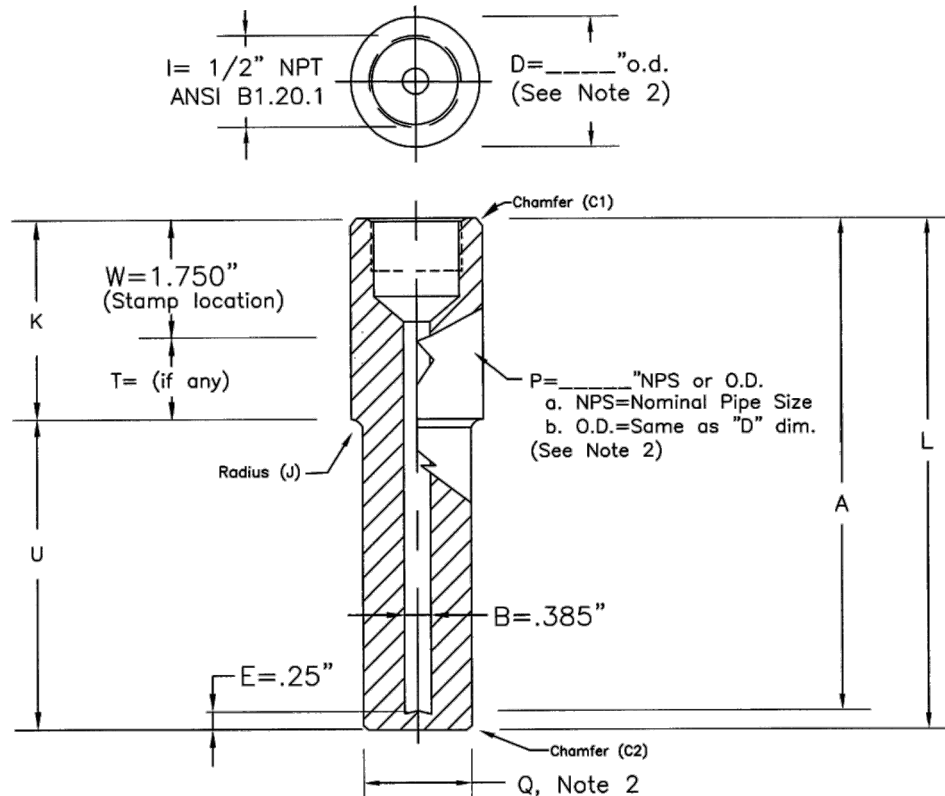

THERMOCOUPLE TECHNOLOGY, INC.

Socket-Weld
Straight
.385" Bore



| S 7 5 | 3/4" NPS Process Connection Style 10067 No Lag Style 10071 Lagging Extension Specifications: See Notes 1,2.a & 3 | 1. STANDARD BIMET LENGTHS: a. No Lag "T" <table border="1"> <thead> <tr> <th>"A"</th> <th>"U"</th> <th>"L"</th> </tr> </thead> <tbody> <tr><td>4"</td><td>2.5</td><td>4.25"</td></tr> <tr><td>6"</td><td>4.5</td><td>6.25"</td></tr> <tr><td>9"</td><td>7.5</td><td>9.25"</td></tr> <tr><td>12"</td><td>10.5</td><td>12.25"</td></tr> <tr><td>15"</td><td>13.5</td><td>15.25"</td></tr> <tr><td>18"</td><td>16.5</td><td>18.25"</td></tr> <tr><td>24"</td><td>22.5</td><td>24.25"</td></tr> </tbody> </table> <table border="1"> <thead> <tr> <th colspan="2">"b. With Lag "T"</th> <th>"A"</th> <th>"U"</th> <th>"T"</th> <th>"L"</th> </tr> </thead> <tbody> <tr><td colspan="2"></td><td>6"</td><td>2.5</td><td>2</td><td>6.25"</td></tr> <tr><td colspan="2"></td><td>9"</td><td>4.5</td><td>3</td><td>9.25"</td></tr> <tr><td colspan="2"></td><td>12"</td><td>7.5</td><td>3</td><td>12.25"</td></tr> <tr><td colspan="2"></td><td>15"</td><td>10.5</td><td>3</td><td>15.25"</td></tr> <tr><td colspan="2"></td><td>18"</td><td>13.5</td><td>3</td><td>18.25"</td></tr> <tr><td colspan="2"></td><td>24"</td><td>19.5</td><td>3</td><td>24.25"</td></tr> </tbody> </table> | "A" | "U" | "L" | 4" | 2.5 | 4.25" | 6" | 4.5 | 6.25" | 9" | 7.5 | 9.25" | 12" | 10.5 | 12.25" | 15" | 13.5 | 15.25" | 18" | 16.5 | 18.25" | 24" | 22.5 | 24.25" | "b. With Lag "T" | | "A" | "U" | "T" | "L" | | | 6" | 2.5 | 2 | 6.25" | | | 9" | 4.5 | 3 | 9.25" | | | 12" | 7.5 | 3 | 12.25" | | | 15" | 10.5 | 3 | 15.25" | | | 18" | 13.5 | 3 | 18.25" | | | 24" | 19.5 | 3 | 24.25" |
|------------------|--|--|------|-----|--------|----|----------|-----------|------|--------|-------|----|--------|-------|--------|--------|--------|--------|--------|--------|-------|--------|--------|-------|--------|--------|------------------|--|-----|-----|-----|-----|--|--|----|-----|---|-------|--|--|----|-----|---|-------|--|--|-----|-----|---|--------|--|--|-----|------|---|--------|--|--|-----|------|---|--------|--|--|-----|------|---|--------|
| | "A" | "U" | "L" | | | | | | | | | | | | | | | | | | | | | | | | | | | | | | | | | | | | | | | | | | | | | | | | | | | | | | | | | | | | | | | | | |
| 4" | 2.5 | 4.25" | | | | | | | | | | | | | | | | | | | | | | | | | | | | | | | | | | | | | | | | | | | | | | | | | | | | | | | | | | | | | | | | | | |
| 6" | 4.5 | 6.25" | | | | | | | | | | | | | | | | | | | | | | | | | | | | | | | | | | | | | | | | | | | | | | | | | | | | | | | | | | | | | | | | | | |
| 9" | 7.5 | 9.25" | | | | | | | | | | | | | | | | | | | | | | | | | | | | | | | | | | | | | | | | | | | | | | | | | | | | | | | | | | | | | | | | | | |
| 12" | 10.5 | 12.25" | | | | | | | | | | | | | | | | | | | | | | | | | | | | | | | | | | | | | | | | | | | | | | | | | | | | | | | | | | | | | | | | | | |
| 15" | 13.5 | 15.25" | | | | | | | | | | | | | | | | | | | | | | | | | | | | | | | | | | | | | | | | | | | | | | | | | | | | | | | | | | | | | | | | | | |
| 18" | 16.5 | 18.25" | | | | | | | | | | | | | | | | | | | | | | | | | | | | | | | | | | | | | | | | | | | | | | | | | | | | | | | | | | | | | | | | | | |
| 24" | 22.5 | 24.25" | | | | | | | | | | | | | | | | | | | | | | | | | | | | | | | | | | | | | | | | | | | | | | | | | | | | | | | | | | | | | | | | | | |
| "b. With Lag "T" | | "A" | "U" | "T" | "L" | | | | | | | | | | | | | | | | | | | | | | | | | | | | | | | | | | | | | | | | | | | | | | | | | | | | | | | | | | | | | | | |
| | | 6" | 2.5 | 2 | 6.25" | | | | | | | | | | | | | | | | | | | | | | | | | | | | | | | | | | | | | | | | | | | | | | | | | | | | | | | | | | | | | | | |
| | | 9" | 4.5 | 3 | 9.25" | | | | | | | | | | | | | | | | | | | | | | | | | | | | | | | | | | | | | | | | | | | | | | | | | | | | | | | | | | | | | | | |
| | | 12" | 7.5 | 3 | 12.25" | | | | | | | | | | | | | | | | | | | | | | | | | | | | | | | | | | | | | | | | | | | | | | | | | | | | | | | | | | | | | | | |
| | | 15" | 10.5 | 3 | 15.25" | | | | | | | | | | | | | | | | | | | | | | | | | | | | | | | | | | | | | | | | | | | | | | | | | | | | | | | | | | | | | | | |
| | | 18" | 13.5 | 3 | 18.25" | | | | | | | | | | | | | | | | | | | | | | | | | | | | | | | | | | | | | | | | | | | | | | | | | | | | | | | | | | | | | | | |
| | | 24" | 19.5 | 3 | 24.25" | | | | | | | | | | | | | | | | | | | | | | | | | | | | | | | | | | | | | | | | | | | | | | | | | | | | | | | | | | | | | | | |
| S 1 0 | 1" NPS Process Connection Style 10068 No Lag Style 10072 Lagging Extension Specifications: See Notes 1,2.a & 3 | 2. MANUFACTURER'S STANDARD O.D.s: a. NPS <table border="1"> <thead> <tr> <th>"D"</th> <th>"Q"</th> <th>"Q"</th> </tr> <tr> <th></th> <th>U > 2.5"</th> <th>U <= 2.5"</th> </tr> </thead> <tbody> <tr><td>3/4"</td><td>1.050"</td><td>.766"</td></tr> <tr><td>1"</td><td>1.315"</td><td>.875"</td></tr> <tr><td>1-1/4"</td><td>1.660"</td><td>1.06"</td></tr> <tr><td>1-1/2"</td><td>1.900"</td><td>1.12"</td></tr> </tbody> </table> b. O.D. <table border="1"> <tbody> <tr><td>1.25"</td><td>1.250"</td><td>.766"</td></tr> <tr><td>1.50"</td><td>1.500"</td><td>.875"</td></tr> </tbody> </table> | "D" | "Q" | "Q" | | U > 2.5" | U <= 2.5" | 3/4" | 1.050" | .766" | 1" | 1.315" | .875" | 1-1/4" | 1.660" | 1.06" | 1-1/2" | 1.900" | 1.12" | 1.25" | 1.250" | .766" | 1.50" | 1.500" | .875" | | | | | | | | | | | | | | | | | | | | | | | | | | | | | | | | | | | | | | | | | | |
| "D" | "Q" | "Q" | | | | | | | | | | | | | | | | | | | | | | | | | | | | | | | | | | | | | | | | | | | | | | | | | | | | | | | | | | | | | | | | | | |
| | U > 2.5" | U <= 2.5" | | | | | | | | | | | | | | | | | | | | | | | | | | | | | | | | | | | | | | | | | | | | | | | | | | | | | | | | | | | | | | | | | | |
| 3/4" | 1.050" | .766" | | | | | | | | | | | | | | | | | | | | | | | | | | | | | | | | | | | | | | | | | | | | | | | | | | | | | | | | | | | | | | | | | | |
| 1" | 1.315" | .875" | | | | | | | | | | | | | | | | | | | | | | | | | | | | | | | | | | | | | | | | | | | | | | | | | | | | | | | | | | | | | | | | | | |
| 1-1/4" | 1.660" | 1.06" | | | | | | | | | | | | | | | | | | | | | | | | | | | | | | | | | | | | | | | | | | | | | | | | | | | | | | | | | | | | | | | | | | |
| 1-1/2" | 1.900" | 1.12" | | | | | | | | | | | | | | | | | | | | | | | | | | | | | | | | | | | | | | | | | | | | | | | | | | | | | | | | | | | | | | | | | | |
| 1.25" | 1.250" | .766" | | | | | | | | | | | | | | | | | | | | | | | | | | | | | | | | | | | | | | | | | | | | | | | | | | | | | | | | | | | | | | | | | | |
| 1.50" | 1.500" | .875" | | | | | | | | | | | | | | | | | | | | | | | | | | | | | | | | | | | | | | | | | | | | | | | | | | | | | | | | | | | | | | | | | | |
| | | 3. TOLERANCES: Reference document: Series S | | | | | | | | | | | | | | | | | | | | | | | | | | | | | | | | | | | | | | | | | | | | | | | | | | | | | | | | | | | | | | | | | | |

STYLES 10067, 10071, 10068, 10072

Thermocouple Technology, Inc.
350 New Street
Quakertown, Pa 18951
Phone: 215-529-9394 FAX: 215-529-9397 www.tteconline.com