

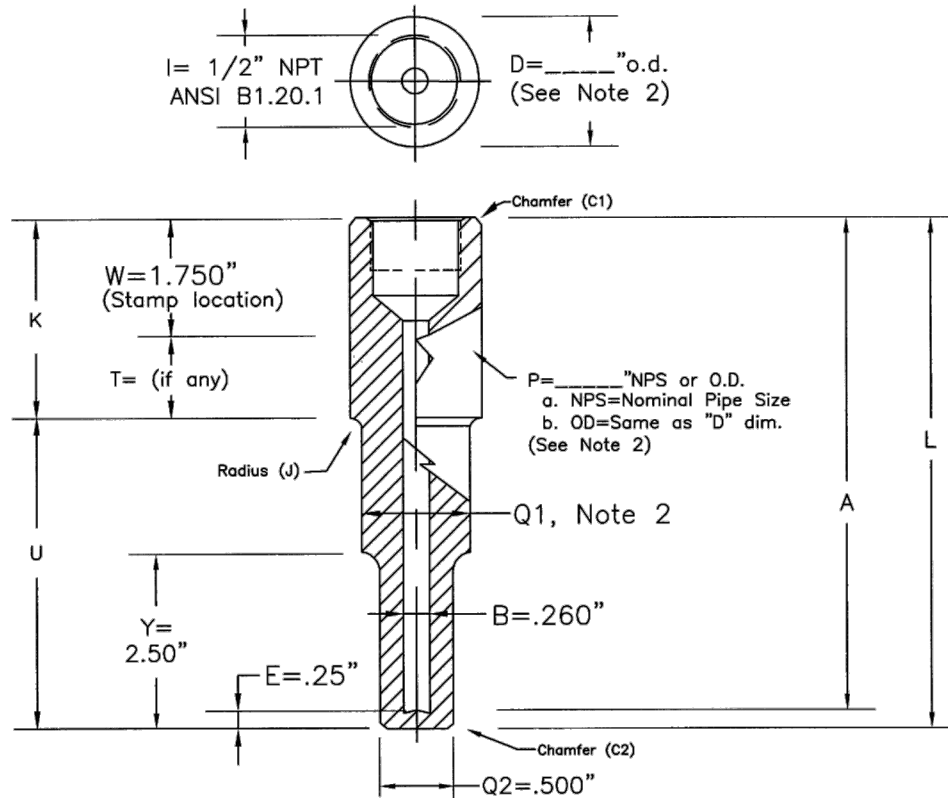

# THERMOCOUPLE TECHNOLOGY, INC.

**Socket-Weld**  
Reduced  
.260" Bore



| <p><b>3/4" NPS Process Connection</b><br/>Style 10061 No Lag<br/>Style 10063 Lagging Extension</p> <p>Specifications: See Notes 1,2.a &amp; 3</p> | <p><b>1. STANDARD BIMET LENGTHS:</b></p> <table border="1"> <thead> <tr> <th colspan="3">a. No Lag "T"</th> <th colspan="3">b. With Lag "T"</th> </tr> <tr> <th>"A"</th> <th>"U"</th> <th>"L"</th> <th>"A"</th> <th>"U"</th> <th>"T" "L"</th> </tr> </thead> <tbody> <tr> <td>4"</td> <td>2.5</td> <td>4.25"</td> <td>6"</td> <td>2.5</td> <td>2 6.25"</td> </tr> <tr> <td>6"</td> <td>4.5</td> <td>6.25"</td> <td>9"</td> <td>4.5</td> <td>3 9.25"</td> </tr> <tr> <td>9"</td> <td>7.5</td> <td>9.25"</td> <td>12"</td> <td>7.5</td> <td>3 12.25"</td> </tr> <tr> <td>12"</td> <td>10.5</td> <td>12.25"</td> <td>15"</td> <td>10.5</td> <td>3 15.25"</td> </tr> <tr> <td>15"</td> <td>13.5</td> <td>15.25"</td> <td>18"</td> <td>13.5</td> <td>3 18.25"</td> </tr> <tr> <td>18"</td> <td>16.5</td> <td>18.25"</td> <td>24"</td> <td>19.5</td> <td>3 24.25"</td> </tr> <tr> <td>24"</td> <td>22.5</td> <td>24.25"</td> <td></td> <td></td> <td></td> </tr> </tbody> </table> | a. No Lag "T"    |                          |                  | b. With Lag "T"          |       |        | "A"   | "U"                  | "L" | "A"    | "U"   | "T" "L"              | 4"     | 2.5    | 4.25" | 6"                   | 2.5    | 2 6.25" | 6"    | 4.5                  | 6.25" | 9" | 4.5 | 3 9.25" | 9" | 7.5 | 9.25" | 12" | 7.5 | 3 12.25" | 12" | 10.5 | 12.25" | 15" | 10.5 | 3 15.25" | 15" | 13.5 | 15.25" | 18" | 13.5 | 3 18.25" | 18" | 16.5 | 18.25" | 24" | 19.5 | 3 24.25" | 24" | 22.5 | 24.25" |  |  |  |
|---|--|------------------|--------------------------|------------------|--------------------------|-------|--------|-------|----------------------|-----|--------|-------|----------------------|--------|--------|-------|----------------------|--------|---------|-------|----------------------|-------|----|-----|---------|----|-----|-------|-----|-----|----------|-----|------|--------|-----|------|----------|-----|------|--------|-----|------|----------|-----|------|--------|-----|------|----------|-----|------|--------|--|--|--|
| a. No Lag "T"   |  |                  | b. With Lag "T"          |                  |                          |       |        |       |                      |     |        |       |                      |        |        |       |                      |        |         |       |                      |       |    |     |         |    |     |       |     |     |          |     |      |        |     |      |          |     |      |        |     |      |          |     |      |        |     |      |          |     |      |        |  |  |  |
| "A"   | "U"  | "L"              | "A"                      | "U"              | "T" "L"                  |       |        |       |                      |     |        |       |                      |        |        |       |                      |        |         |       |                      |       |    |     |         |    |     |       |     |     |          |     |      |        |     |      |          |     |      |        |     |      |          |     |      |        |     |      |          |     |      |        |  |  |  |
| 4"  | 2.5  | 4.25"            | 6"                       | 2.5              | 2 6.25"                  |       |        |       |                      |     |        |       |                      |        |        |       |                      |        |         |       |                      |       |    |     |         |    |     |       |     |     |          |     |      |        |     |      |          |     |      |        |     |      |          |     |      |        |     |      |          |     |      |        |  |  |  |
| 6"  | 4.5  | 6.25"            | 9"                       | 4.5              | 3 9.25"                  |       |        |       |                      |     |        |       |                      |        |        |       |                      |        |         |       |                      |       |    |     |         |    |     |       |     |     |          |     |      |        |     |      |          |     |      |        |     |      |          |     |      |        |     |      |          |     |      |        |  |  |  |
| 9"  | 7.5  | 9.25"            | 12"                      | 7.5              | 3 12.25"                 |       |        |       |                      |     |        |       |                      |        |        |       |                      |        |         |       |                      |       |    |     |         |    |     |       |     |     |          |     |      |        |     |      |          |     |      |        |     |      |          |     |      |        |     |      |          |     |      |        |  |  |  |
| 12"   | 10.5   | 12.25"           | 15"                      | 10.5             | 3 15.25"                 |       |        |       |                      |     |        |       |                      |        |        |       |                      |        |         |       |                      |       |    |     |         |    |     |       |     |     |          |     |      |        |     |      |          |     |      |        |     |      |          |     |      |        |     |      |          |     |      |        |  |  |  |
| 15"   | 13.5   | 15.25"           | 18"                      | 13.5             | 3 18.25"                 |       |        |       |                      |     |        |       |                      |        |        |       |                      |        |         |       |                      |       |    |     |         |    |     |       |     |     |          |     |      |        |     |      |          |     |      |        |     |      |          |     |      |        |     |      |          |     |      |        |  |  |  |
| 18"   | 16.5   | 18.25"           | 24"                      | 19.5             | 3 24.25"                 |       |        |       |                      |     |        |       |                      |        |        |       |                      |        |         |       |                      |       |    |     |         |    |     |       |     |     |          |     |      |        |     |      |          |     |      |        |     |      |          |     |      |        |     |      |          |     |      |        |  |  |  |
| 24"   | 22.5   | 24.25"           |                          |                  |                          |       |        |       |                      |     |        |       |                      |        |        |       |                      |        |         |       |                      |       |    |     |         |    |     |       |     |     |          |     |      |        |     |      |          |     |      |        |     |      |          |     |      |        |     |      |          |     |      |        |  |  |  |
| <p><b>1" NPS Process Connection</b><br/>Style 10062 No Lag<br/>Style 10064 Lagging Extension</p> <p>Specifications: See Notes 1,2.a &amp; 3</p>   | <p><b>2. MANUFACTURER'S STANDARD O.D.s:</b></p> <table border="1"> <thead> <tr> <th>a. NPS</th> <th>"D"</th> <th>"Q1"<br/>U &gt; 2.5"</th> <th>"Q1" &amp; "Q2"<br/>U &lt;= 2.5"</th> </tr> </thead> <tbody> <tr> <td>3/4"</td> <td>1.050"</td> <td>.750"</td> <td>.500" Straight Shank</td> </tr> <tr> <td>1"</td> <td>1.315"</td> <td>.875"</td> <td>.750" Straight Shank</td> </tr> <tr> <td>1-1/4"</td> <td>1.660"</td> <td>1.00"</td> <td>.875" Straight Shank</td> </tr> <tr> <td>1-1/2"</td> <td>1.900"</td> <td>1.12"</td> <td>1.00" Straight Shank</td> </tr> </tbody> </table>  | a. NPS           | "D"                      | "Q1"<br>U > 2.5" | "Q1" & "Q2"<br>U <= 2.5" | 3/4"  | 1.050" | .750" | .500" Straight Shank | 1"  | 1.315" | .875" | .750" Straight Shank | 1-1/4" | 1.660" | 1.00" | .875" Straight Shank | 1-1/2" | 1.900"  | 1.12" | 1.00" Straight Shank |       |    |     |         |    |     |       |     |     |          |     |      |        |     |      |          |     |      |        |     |      |          |     |      |        |     |      |          |     |      |        |  |  |  |
| a. NPS  | "D"  | "Q1"<br>U > 2.5" | "Q1" & "Q2"<br>U <= 2.5" |                  |                          |       |        |       |                      |     |        |       |                      |        |        |       |                      |        |         |       |                      |       |    |     |         |    |     |       |     |     |          |     |      |        |     |      |          |     |      |        |     |      |          |     |      |        |     |      |          |     |      |        |  |  |  |
| 3/4"  | 1.050"   | .750"            | .500" Straight Shank     |                  |                          |       |        |       |                      |     |        |       |                      |        |        |       |                      |        |         |       |                      |       |    |     |         |    |     |       |     |     |          |     |      |        |     |      |          |     |      |        |     |      |          |     |      |        |     |      |          |     |      |        |  |  |  |
| 1"  | 1.315"   | .875"            | .750" Straight Shank     |                  |                          |       |        |       |                      |     |        |       |                      |        |        |       |                      |        |         |       |                      |       |    |     |         |    |     |       |     |     |          |     |      |        |     |      |          |     |      |        |     |      |          |     |      |        |     |      |          |     |      |        |  |  |  |
| 1-1/4"  | 1.660"   | 1.00"            | .875" Straight Shank     |                  |                          |       |        |       |                      |     |        |       |                      |        |        |       |                      |        |         |       |                      |       |    |     |         |    |     |       |     |     |          |     |      |        |     |      |          |     |      |        |     |      |          |     |      |        |     |      |          |     |      |        |  |  |  |
| 1-1/2"  | 1.900"   | 1.12"            | 1.00" Straight Shank     |                  |                          |       |        |       |                      |     |        |       |                      |        |        |       |                      |        |         |       |                      |       |    |     |         |    |     |       |     |     |          |     |      |        |     |      |          |     |      |        |     |      |          |     |      |        |     |      |          |     |      |        |  |  |  |
|   | <p><b>b. O.D.</b></p> <table border="1"> <tbody> <tr> <td>1.25"</td> <td>1.250"</td> <td>.750"</td> <td>.500" Straight Shank</td> </tr> <tr> <td>1.50"</td> <td>1.500"</td> <td>.875"</td> <td>.750" Straight Shank</td> </tr> </tbody> </table> <p><b>3. TOLERANCES:</b><br/>Reference document: Series S</p>   | 1.25"            | 1.250"                   | .750"            | .500" Straight Shank     | 1.50" | 1.500" | .875" | .750" Straight Shank |     |        |       |                      |        |        |       |                      |        |         |       |                      |       |    |     |         |    |     |       |     |     |          |     |      |        |     |      |          |     |      |        |     |      |          |     |      |        |     |      |          |     |      |        |  |  |  |
| 1.25"   | 1.250"   | .750"            | .500" Straight Shank     |                  |                          |       |        |       |                      |     |        |       |                      |        |        |       |                      |        |         |       |                      |       |    |     |         |    |     |       |     |     |          |     |      |        |     |      |          |     |      |        |     |      |          |     |      |        |     |      |          |     |      |        |  |  |  |
| 1.50"   | 1.500"   | .875"            | .750" Straight Shank     |                  |                          |       |        |       |                      |     |        |       |                      |        |        |       |                      |        |         |       |                      |       |    |     |         |    |     |       |     |     |          |     |      |        |     |      |          |     |      |        |     |      |          |     |      |        |     |      |          |     |      |        |  |  |  |

STYLES 10061, 10063, 10062, 10064

Thermocouple Technology, Inc.  
350 New Street  
Quakertown, Pa 18951  
Phone: 215-529-9394 FAX: 215-529-9397 www.tteconline.com