

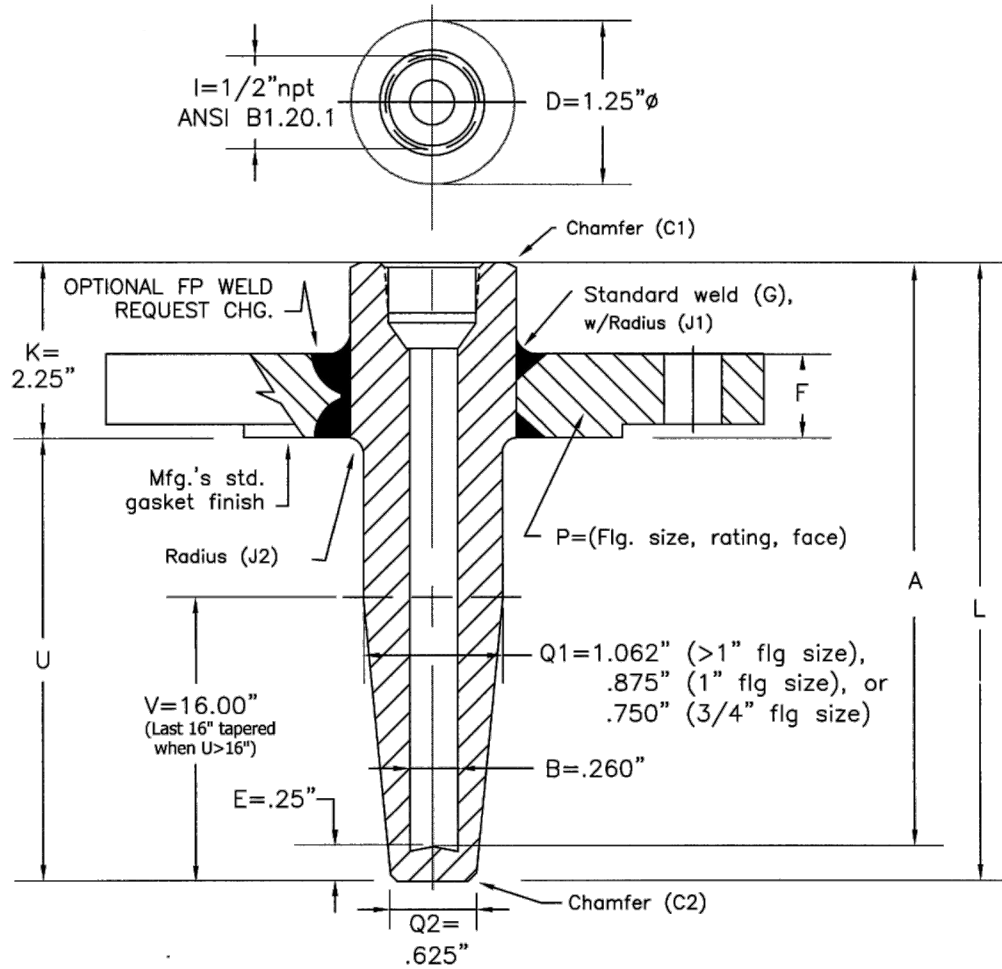

# THERMOCOUPLE TECHNOLOGY, INC.

**Flanged  
Tapered  
.260" Bore**



<p><b>3/4" Flange Size Connection Style 10044</b></p> <p><b>1" Flange Size Connection Style 10045</b></p> <p>See Note #2 &amp; #3 for flange rating &amp; facings</p> <p>Specify flange size rating &amp; face</p>	<p><b>1. STANDARD BIMET LENGTHS:</b></p> <table border="1"> <thead> <tr> <th>"A"</th> <th>"U"</th> <th>"L"</th> </tr> </thead> <tbody> <tr><td>4"</td><td>2</td><td>4.25"</td></tr> <tr><td>6"</td><td>4</td><td>6.25"</td></tr> <tr><td>9"</td><td>7</td><td>9.25"</td></tr> <tr><td>12"</td><td>10</td><td>12.25"</td></tr> <tr><td>15"</td><td>13</td><td>15.25"</td></tr> <tr><td>18"</td><td>16</td><td>18.25"</td></tr> <tr><td>24"</td><td>22</td><td>24.25"</td></tr> </tbody> </table>	"A"	"U"	"L"	4"	2	4.25"	6"	4	6.25"	9"	7	9.25"	12"	10	12.25"	15"	13	15.25"	18"	16	18.25"	24"	22	24.25"
"A"	"U"	"L"																							
4"	2	4.25"																							
6"	4	6.25"																							
9"	7	9.25"																							
12"	10	12.25"																							
15"	13	15.25"																							
18"	16	18.25"																							
24"	22	24.25"																							
<p><b>1.5" &amp; Larger Flange Size Connection Style 10046</b></p>	<p><b>2. STANDARD FLANGE RATINGS:</b> 150#, 300#, 600#, 900/1500#, 1500#, 2500#</p> <p><b>3. STANDARD FLANGE FACINGS</b> RF: Raised FF: Flat Face RTJ: Ring Type Joint</p> <p><b>4. TOLERANCES:</b> Reference document: Series F &amp; PFD</p>																								

STYLES 10044, 10045, 10046

Thermocouple Technology, Inc.  
350 New Street  
Quakertown, Pa 18951  
Phone: 215-529-9394 FAX: 215-529-9397 www.tteconline.com