

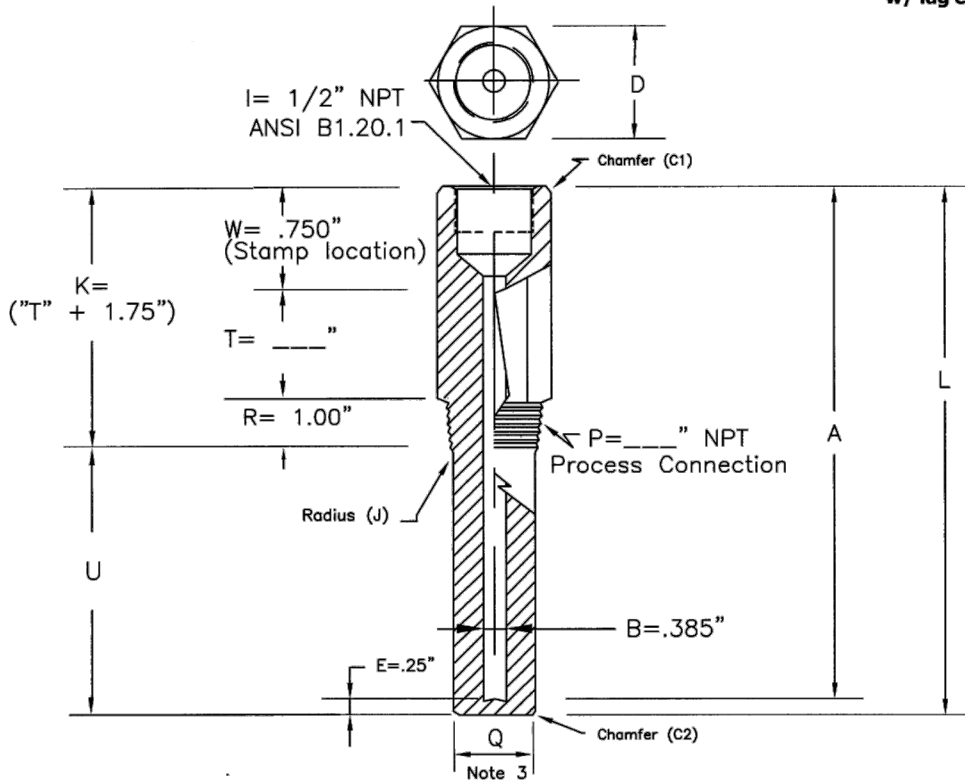

THERMOCOUPLE TECHNOLOGY, INC.

Threaded
 Straight
 .385" Bore
 w/ lag ext.



T 5 0	<p>1/2" Process Connection Style 10030 Specifications: See Notes 1-4 a. Minimum lag length = .250" and b. "D" = 1-1/8" hex, See Note 2</p>	<p>1. STANDARD BIMET LENGTHS:</p> <table border="1"> <thead> <tr> <th>"A"</th> <th>"U"</th> <th>"T"</th> <th>"L"</th> </tr> </thead> <tbody> <tr> <td>6"</td> <td>2.5</td> <td>2</td> <td>6.25"</td> </tr> <tr> <td>9"</td> <td>4.5</td> <td>3</td> <td>9.25"</td> </tr> <tr> <td>12"</td> <td>7.5</td> <td>3</td> <td>12.25"</td> </tr> <tr> <td>15"</td> <td>10.5</td> <td>3</td> <td>15.25"</td> </tr> <tr> <td>18"</td> <td>13.5</td> <td>3</td> <td>18.25"</td> </tr> <tr> <td>24"</td> <td>19.5</td> <td>3</td> <td>24.25"</td> </tr> </tbody> </table> <p>2. STANDARD HEX MATERIALS: 304:304/Lss 316:316/Lss CS:CS 1018 BR: Brass a. Other material grades are available only in round bar with (2) wrench flats.</p> <p>3. STANDARD SHANK O.D.s: T50 Q1 = .680" T75: Q1 = .766" T10: Q1 = .875"</p> <p>4. TOLERANCES: Reference document: Series T</p>	"A"	"U"	"T"	"L"	6"	2.5	2	6.25"	9"	4.5	3	9.25"	12"	7.5	3	12.25"	15"	10.5	3	15.25"	18"	13.5	3	18.25"	24"	19.5	3	24.25"
"A"	"U"		"T"	"L"																										
6"	2.5		2	6.25"																										
9"	4.5	3	9.25"																											
12"	7.5	3	12.25"																											
15"	10.5	3	15.25"																											
18"	13.5	3	18.25"																											
24"	19.5	3	24.25"																											
T 7 5	<p>3/4" Process Connection Style 10013 Specifications: See Notes 1-4 "D" = 1-1/8" hex, See Note 2</p>																													
T 1 0	<p>1" Process Connection Style 10014 Specifications: See Notes 1-4 "D" = 1-3/8" hex, See Note 2</p>																													

STYLES 10030, 10013, 10014

Thermocouple Technology, Inc.
 350 New Street
 Quakertown, Pa 18951
 Phone: 215-529-9394 FAX: 215-529-9397 www.tteconline.com