

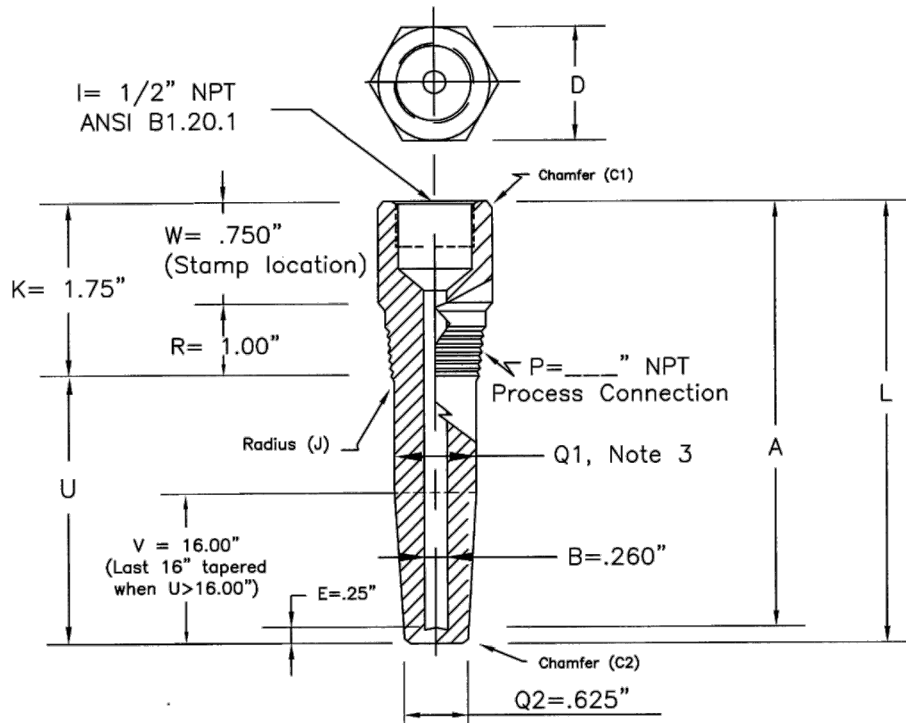

THERMOCOUPLE TECHNOLOGY, INC.

Threaded
Tapered
.260" Bore



T 5 0	<p>1/2" Process Connection Style 10031 Specifications: See Notes 1-4 a. "W" = 1.0", "R" = .750" and b. "D" = 1-1/8" hex, See Note 2</p>	<p>1. STANDARD BIMET LENGTHS:</p> <table border="1"> <thead> <tr> <th>"A"</th> <th>"U"</th> <th>"L"</th> </tr> </thead> <tbody> <tr> <td>2.5"</td> <td>1</td> <td>2.75"</td> </tr> <tr> <td>2.5"</td> <td>1.625</td> <td>See Limited Space Series</td> </tr> <tr> <td>4"</td> <td>2.5</td> <td>4.25"</td> </tr> <tr> <td>6"</td> <td>4.5</td> <td>6.25"</td> </tr> <tr> <td>9"</td> <td>7.5</td> <td>9.25"</td> </tr> <tr> <td>12"</td> <td>10.5</td> <td>12.25"</td> </tr> <tr> <td>15"</td> <td>13.5</td> <td>15.25"</td> </tr> <tr> <td>18"</td> <td>16.5</td> <td>18.25" (Last 16" tapered)</td> </tr> <tr> <td>24"</td> <td>22.5</td> <td>24.25" (Last 16" tapered)</td> </tr> </tbody> </table> <p>2. STANDARD HEX MATERIALS: 304:304/Lss 316:316/Lss CS:CS 1018 BR: Brass a. Other material grades are available only in round bar with (2) wrench flats.</p> <p>3. STANDARD SHANK O.D.s: T50 Q1 = .680" T75: Q1 = .875" T10: Q1 = 1.062"</p> <p>4. TOLERANCES: Reference document: Series T</p>	"A"	"U"	"L"	2.5"	1	2.75"	2.5"	1.625	See Limited Space Series	4"	2.5	4.25"	6"	4.5	6.25"	9"	7.5	9.25"	12"	10.5	12.25"	15"	13.5	15.25"	18"	16.5	18.25" (Last 16" tapered)	24"	22.5	24.25" (Last 16" tapered)
"A"	"U"		"L"																													
2.5"	1		2.75"																													
2.5"	1.625	See Limited Space Series																														
4"	2.5	4.25"																														
6"	4.5	6.25"																														
9"	7.5	9.25"																														
12"	10.5	12.25"																														
15"	13.5	15.25"																														
18"	16.5	18.25" (Last 16" tapered)																														
24"	22.5	24.25" (Last 16" tapered)																														
T 7 5	<p>3/4" Process Connection Style 10007 Specifications: See Notes 1-4 "D" = 1-1/8" hex, See Note 2</p>																															
T 1 0	<p>1" Process Connection Style 10008 Specifications: See Notes 1-4 "D" = 1-3/8" hex, See Note 2</p>																															

STYLES 10031, 10007, 10008

Thermocouple Technology, Inc.
350 New Street
Quakertown, Pa 18951
Phone: 215-529-9394 FAX: 215-529-9397 www.tteconline.com